

BTS 75V/D, 75V BF/D, 80/D 3/4" OFFSET PACKAGES



1 Slide washer over tapered square end of spindle until fully seated in groove. Fasten spindle with spindle screw provided. **Tighten securely with 5mm HEX KEY.**

SPINDLE SCREW
SPINDLE
WASHER

CRITICAL
WASHER MUST
BE INSTALLED.

5 Install bottom arm.

BOTTOM OF DOOR
BOTTOM ARM

2 Center closer in cement case. Tighten fastening screws.

FASTENING SCREWS

6 Install door.

With door parallel to frame, place bottom arm onto closer spindle. Align door and frame portions of top pivot. Install pivot pin, set screw and cover cap (See step #4). Install cover over bottom arm with screw provided.

3 Install closer and cement case in floor.

Top of cement case must be flush with finished floor. Cement case must be level and installed parallel to frame. Spindle center line must be accurately located. Grout cement case in place.

FINISHED FLOOR

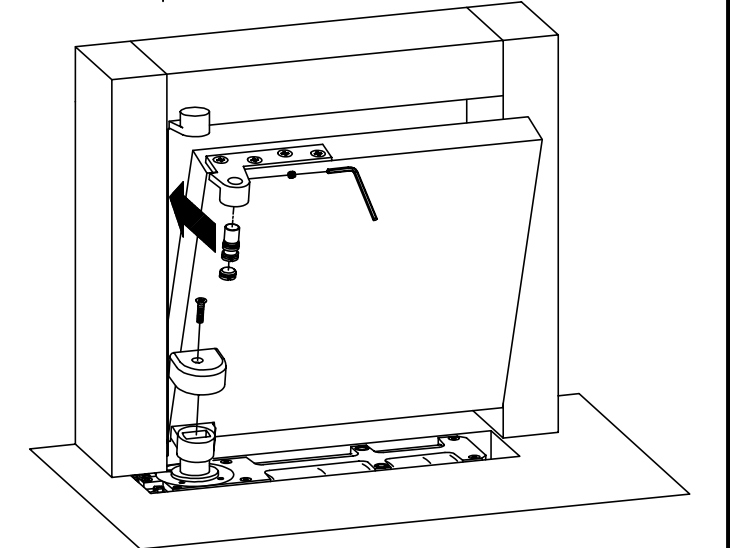

4 Install top pivot.

Remove set screw, cover cap, pivot pin and then install top pivot.

FRAME PORTION
SET SCREW
1/8" HEX KEY
DOOR PORTION
PIVOT PIN
UNDERCUT
COVER CAP

7 Adjust bottom door clearances. (If necessary)

Closer can be raised approximately 5/32" within the cement case. Loosen fastening screws "A". Turn height adjustment screws "B" clockwise until desired height is obtained. **Closer must remain level!** Re-tighten fastening screws "A". **If more clearance is necessary, change spindle to appropriate size.**

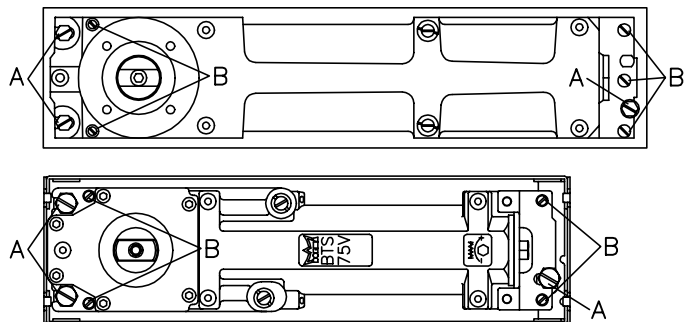

8 Adjust closing speed.



BTS 80

VALVE "D"—controls closing speed from approx. 180°–80°.

VALVE "E"—controls closing speed from approx. 80°–0°.

DELAYED ACTION: Turn valve "D" clockwise until desired delay time is obtained.

HOLD OPEN: Turn valve "D" completely clockwise. Door will hold at any point beyond approx. 80°. Allow for approx. 4" fall away when considering hold open position. To release door, manually pull door closed a few inches.

VALVE "C"—controls position at which hold open or delayed action will begin to occur. Clockwise turns increase angle (105° max.). Counterclockwise turns decrease angle (75° min.).

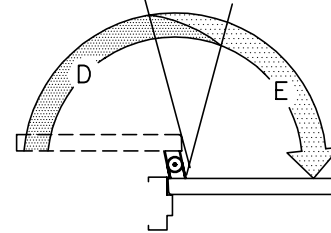
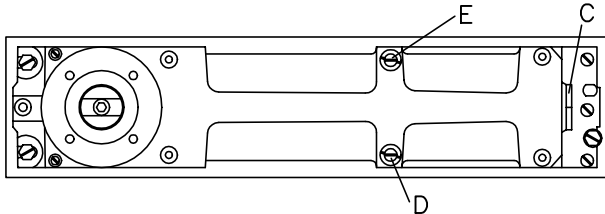

BTS 75V

VALVE "D"—controls closing speed from approx. 175°–15°.

VALVE "E"—controls closing speed from approx. 15°–0°.

BTS 75V BF

VALVE "D"—controls closing speed from approx. 175°–70°.

VALVE "E"—controls closing speed from approx. 70°–0°.

DELAYED ACTION : Turn valve "D" until desired delay time is obtained.

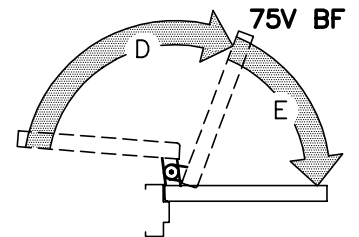
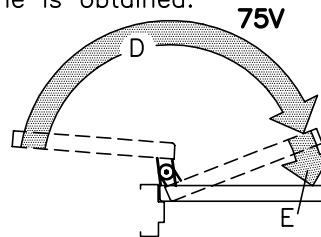
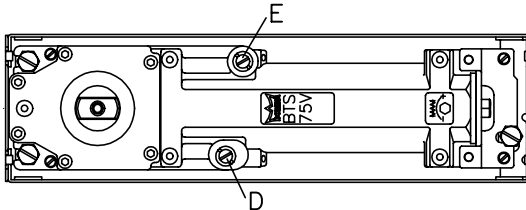

HOLD OPEN: Mechanical hold open is available at 90° or 105° as an option when ordering closer.

9 **BTS 75V/75V BF ONLY.**

Adjust spring tension, if required.

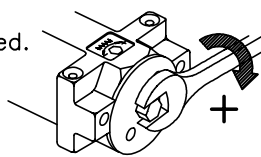

CRITICAL

BTS75VBF—Adjust only if more spring tension is required to positively close and latch the door. Depending on opening conditions, a door adjusted to meet barrier-free forces may not have sufficient power to reliably close and latch the door.

BTS75V—Adjust according to chart.

BTS75V	DOOR WIDTH				FULL TURNS OF SPRING ADJUSTING NUT
	EXTERIOR		INTERIOR		
	INCHES	(MM)	INCHES	(MM)	
	—	—	2'-6"	762	3
	2'-6"	762	3'-0"	914	6
	3'-0"	914	3'-6"	1067	10

NOTE: "MAX. 12 TURNS FROM MINIMUM SETTING".

11 Install cover plate or threshold.

Trim cover plate as required to match profile of pivot jamb. Install cover plate with four screws provided. Press tab in place behind spindle. If threshold is installed, do not anchor threshold to closer body since closer is adjustable within cement case.

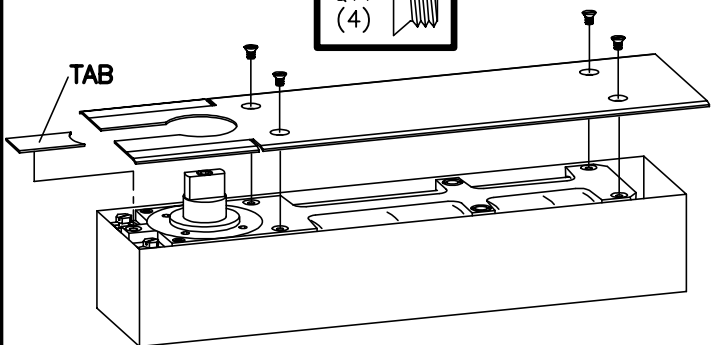

10 Sealing compound (Optional)

Sealing compound is recommended for exterior doors or areas with excessive moisture. Make all final adjustments before adding compound. Refer to instructions packed with compound for full details.

12 If intermediate pivot is to be used, refer to installation instructions packed with pivot.

CEMENT CASE

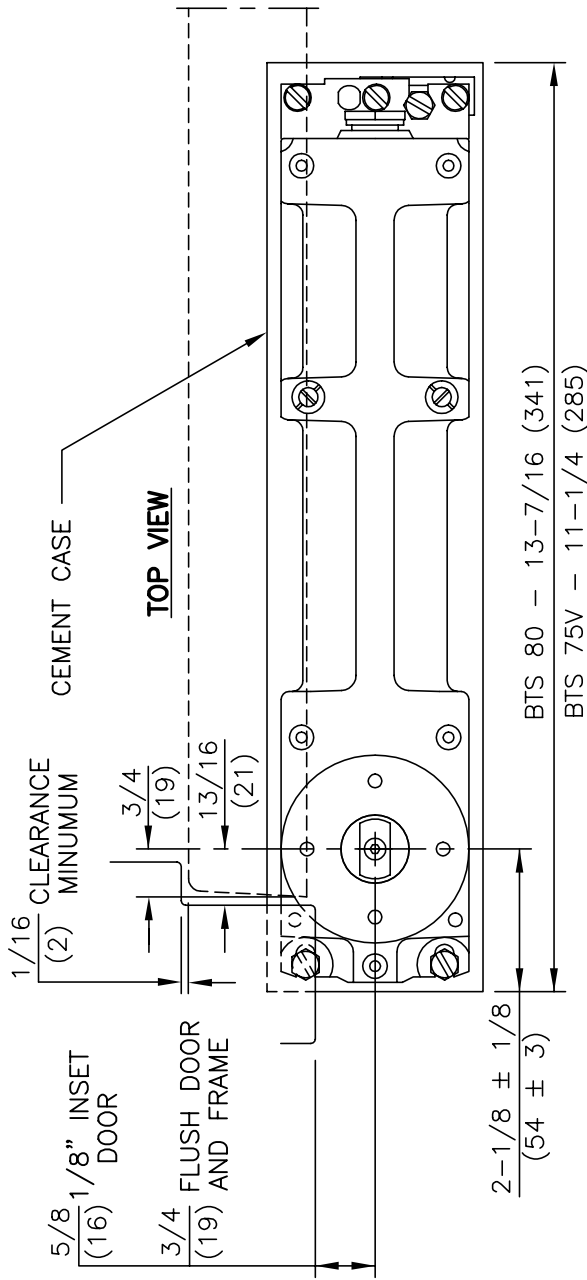

NOTES

1. DO NOT SCALE DRAWING.
2. DIMENSIONS ARE IN INCHES/(mm).
3. TOP OF CEMENT CASE MUST BE FLUSH WITH FINISH FLOOR LINE.
4. CEMENT CASE MUST BE LEVEL AND PARALLEL TO FRAME.
5. INSTALL CEMENT CASE WITH CLOSER CENTERED IN CASE.
6. 1/8" INSET INSTALLATION SHOWN.

SIDE VIEW

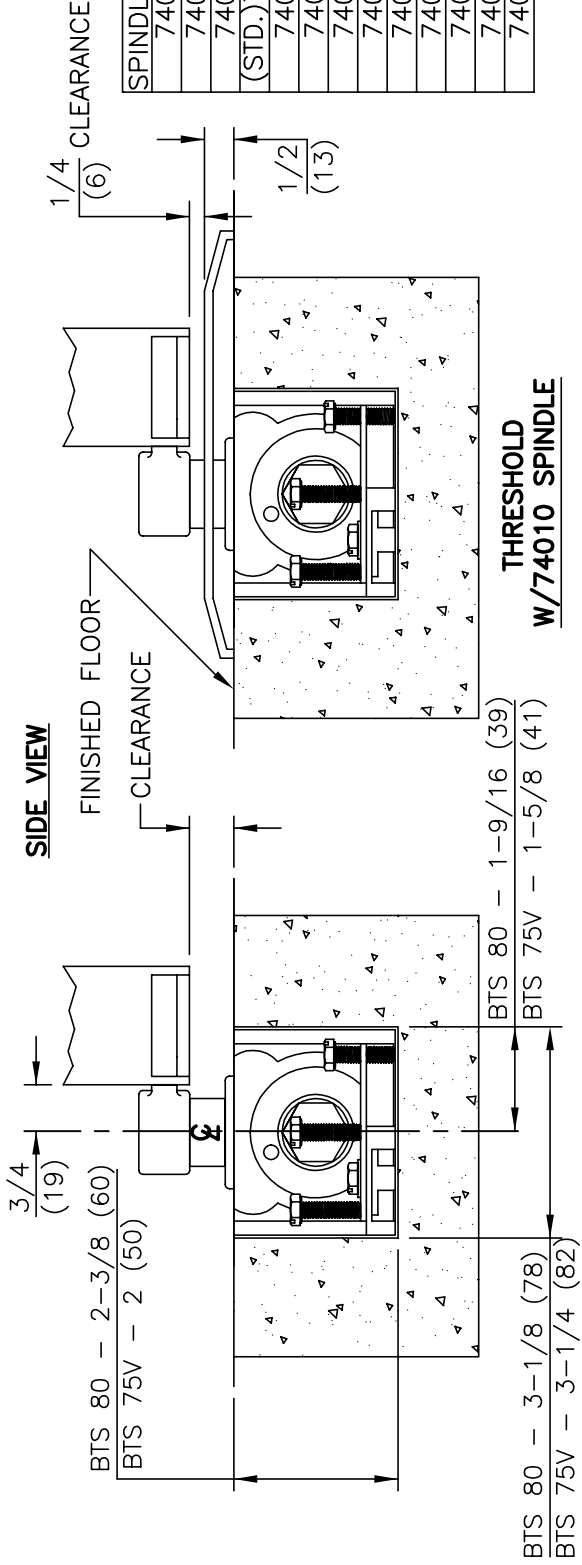

SPINDLE NO.	CLEARANCE
74003	5/16"
74005	1/2"
74007	5/8"
(STD.)74010	3/4"
74012	13/16"
74015	7/8"
74020	1-1/8"
74025	1-5/16"
74030	1-1/2"
74035	1-11/16"
74040	1-7/8"
74045	2-1/16"
74050	2-5/16"

TOP PIVOT

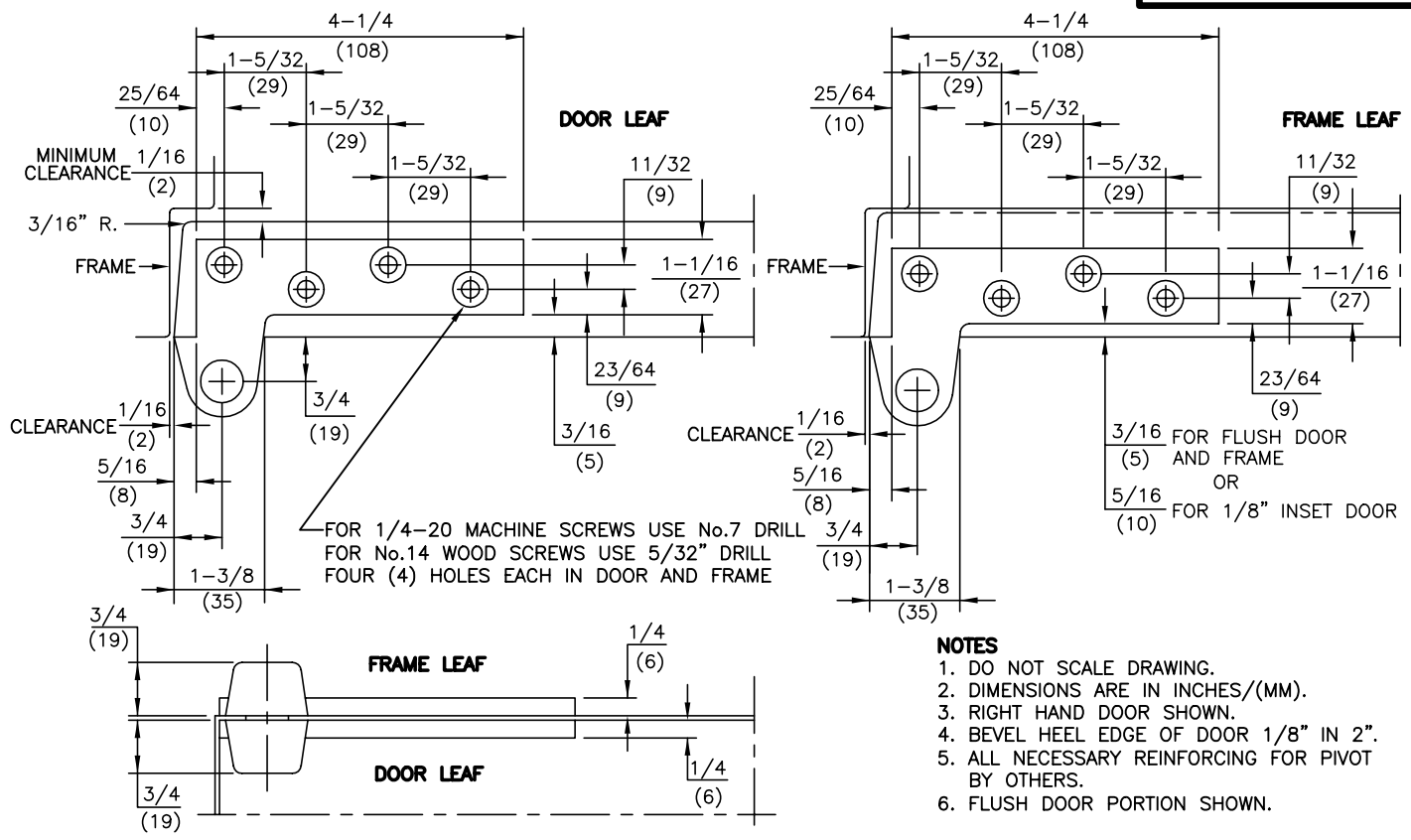

BOTTOM ARM

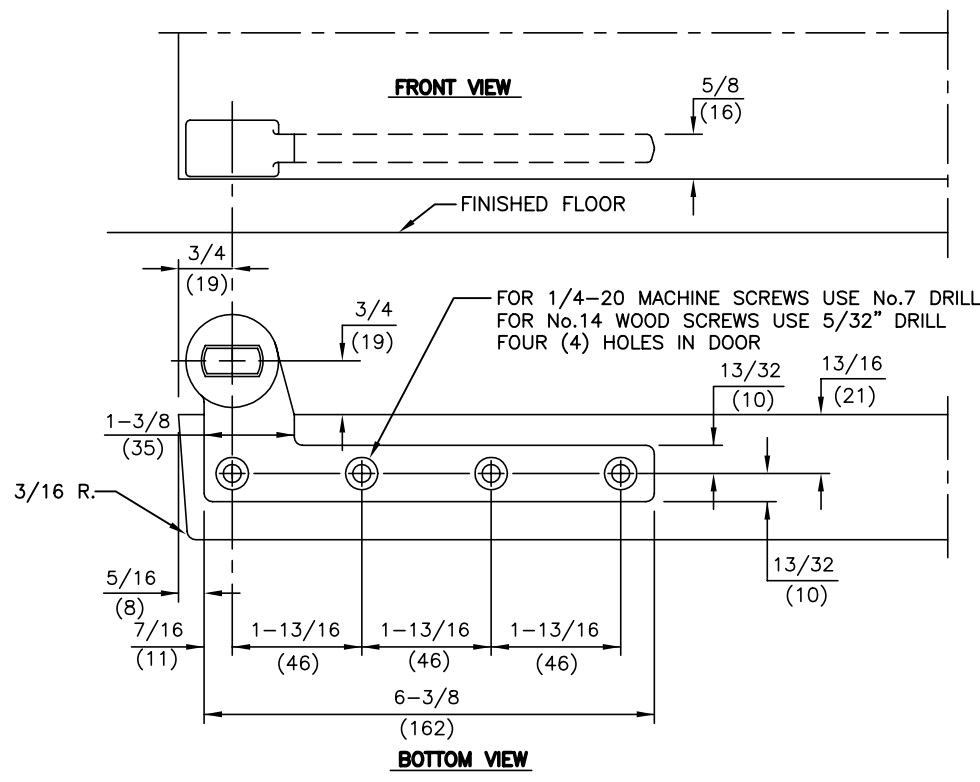

- NOTES**
1. DO NOT SCALE DRAWING.
 2. DIMENSIONS ARE IN INCHES/(MM).
 3. RIGHT HAND DOOR SHOWN.
 4. BEVEL HEEL EDGE OF DOOR 1/8" IN 2".
 5. ALL NECESSARY REINFORCEMENT FOR ARM BY OTHERS.