

Closing speeds can be adjusted to suit local conditions and requirements. Label on closer face designates the purpose of each adjustment screw. Adjustments are for speed control.

Closer Type

This closer is one of three types as follows:

1. Non hold-open factory set. No hold-open adjustments.
2. Automatic hold-open factory set. No hold-open adjustment.

Spring Power Adjustments

This closer can be adjusted for increased or decreased spring power.

These adjustments if required should be done by an authorized repair agency.

Repairs, parts replacement or internal adjustments must be done by a Rixson authorized repair agency. Consult www.rixsondoorcontrols.com for an authorized repair agency in your area.



Installation Instructions

3040W (04-02)

W30-W40 Floor Closer

Center Hung
Double Acting
Non-Handed

Wood Door Installation

Template

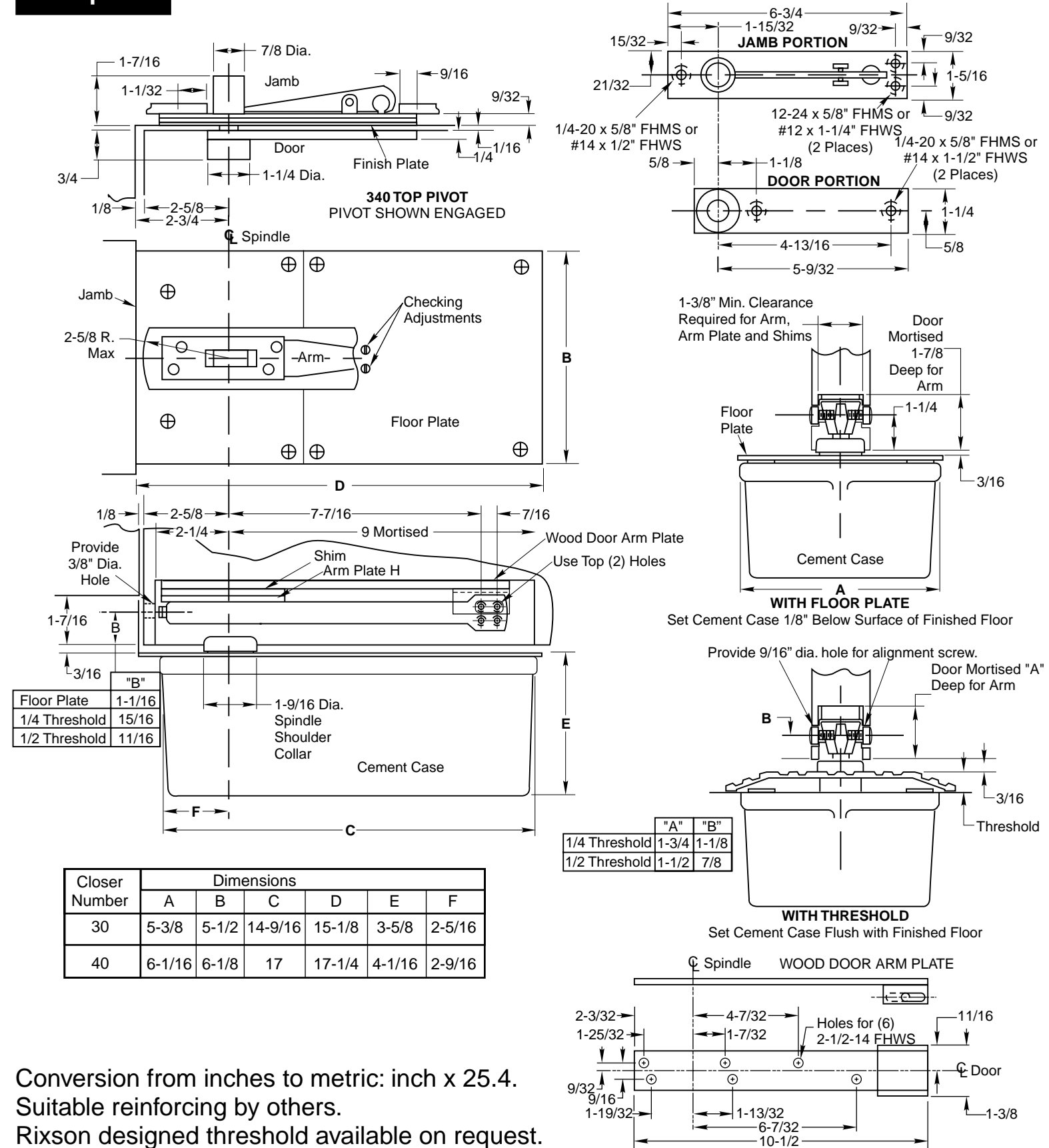

Conversion from inches to metric: inch x 25.4.
Suitable reinforcing by others.
Rixson designed threshold available on request.

How To Determine Hand of Door

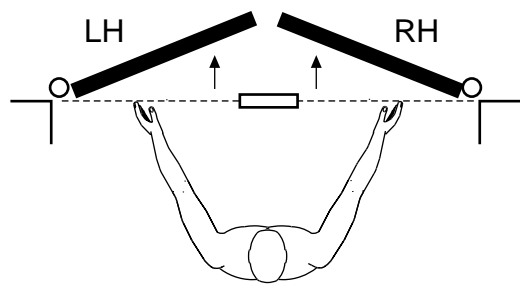

Face a door swinging open away from you. If it opens to the right, it is right hand. If it opens to the left, it is left hand.
NOTE: This product allows the door to swing in both directions.

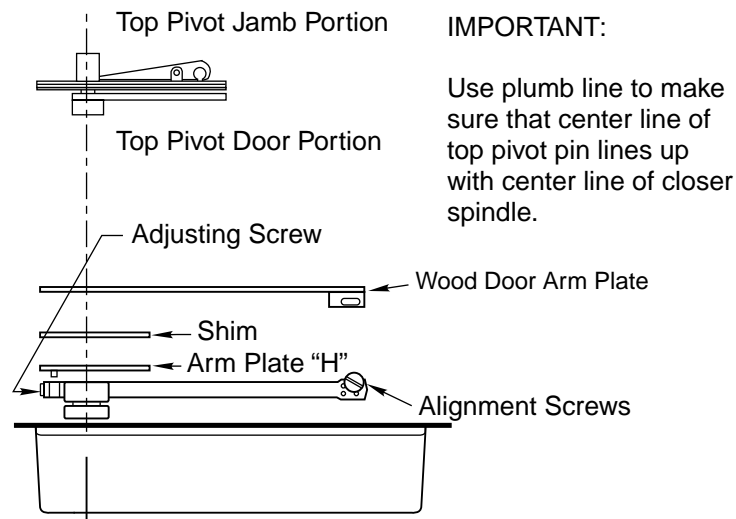

IMPORTANT:

Use plumb line to make sure that center line of top pivot pin lines up with center line of closer spindle.

3. Install Pivot and Closer Arm

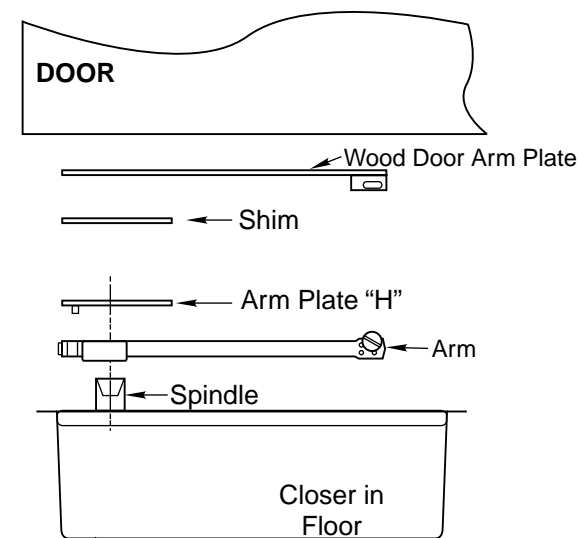

- A. Install top pivot in door per template.
- B. Install top pivot in jamb per template.
- C. Centerline of pivot pin should line up with centerline of spindle. Use plumb line to assure accuracy.
- D. Mortise door for arm and arm plates. Install arm plate, shim, and arm. (If threshold is used, refer to template).
- E. Drill two 9/16" dia. holes for arm alignment screws. Drill 3/8" hole at heel edge of door for adjusting screw.

Installation Instructions

1. Locating Closer

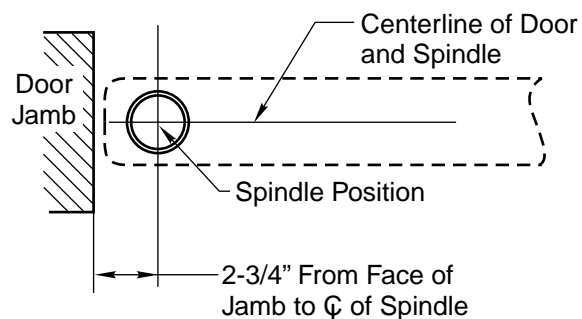

- A. Measure 2-3/4" out from door jamb on centerline of door. This is the location of the spindle center.

2. Install Cement Case in Floor

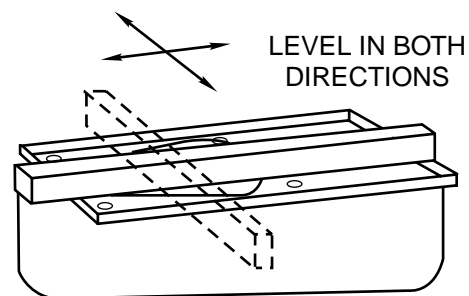

- A. For floor plate application: Cement case is set 1/8" (3.2mm) below floor level.
- B. For threshold application: Cement case is set flush with floor.
- C. Set cement case in floor and block in position.
- D. Case should be parallel with center line of door.
- E. CEMENT CASE SHOULD BE LEVEL. Place levels per illustration.
- F. Grout in cement case with closer. Cement should not get between closer and case.

4. Hang Door

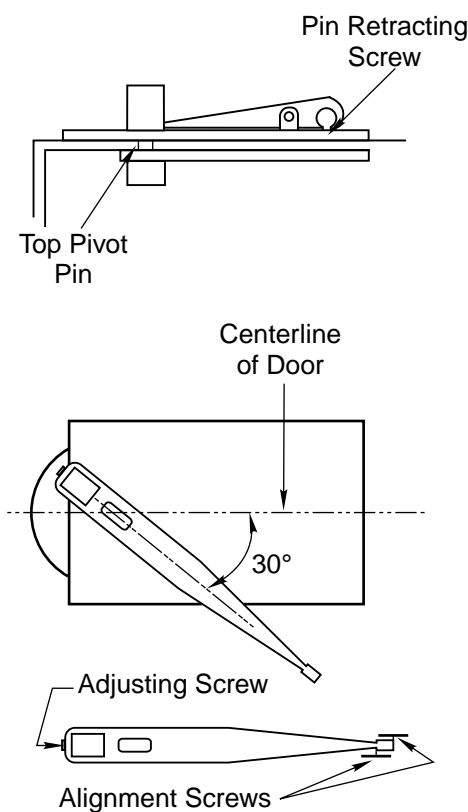

CAUTION: Closer is shipped with "valve" screws down. DO NOT FORCE VALVE DOWN.

- A. Retract top pivot pin by turning retracting pin screw counter-clockwise (see illustration).
- B. With arm on spindle, turn spindle until arm is in 30° open position (see illustration).
- C. Set door on spindle. DO NOT ATTEMPT TO CLOSE DOOR.
- D. Align two portions of top pivot and turn pin retracting screw clockwise to engage top pivot pin.
- E. Open door to 60° or more and turn valve screws counterclockwise. Door will then close.
- F. If necessary, turn adjusting screw at bottom of heel edge of door to equalize side jamb clearances.
- G. Adjust arm alignment screws equally from each side to center door in doorway.